



Office

Rm 4409, No. 372, Huanshi
Dong Road, Yuexiu District,
Guangzhou, 510060,
China



Website:

www.pydlife.com



Mob/WhatsApp:

+86 19924795321



E-mail:

sales01@pydlife.com



30oz SKINNY TUMBLER HEAT PRESS

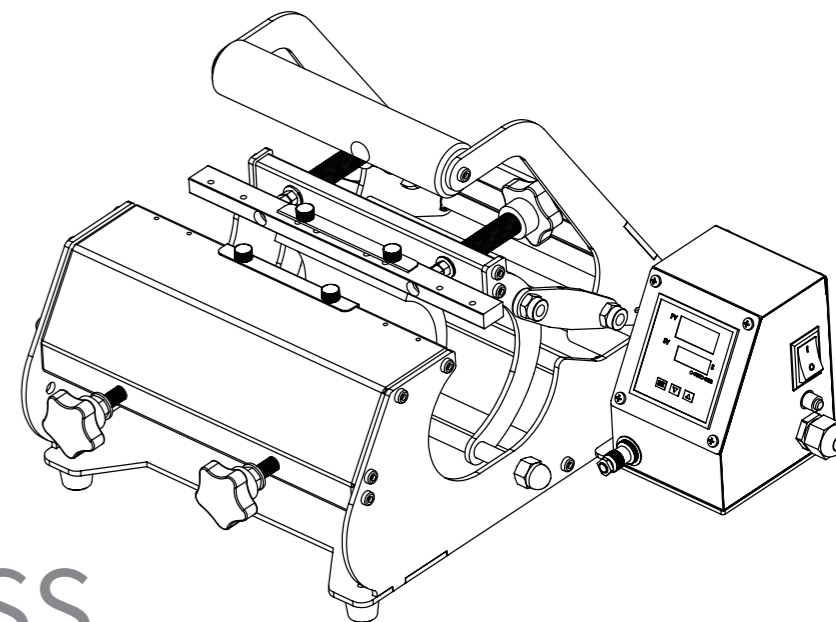

USER MANUAL

TMP30BL



STRUCTURE

Time Range	0-999 seconds	Temperature	0~240 °C, 0~464 °F
Voltage	220V / 110V	Max. Printable Size	30oz tumbler, 8cm in diameter, 24cm in height
Power	698W	Packing	Foam packing, 1 set/ctn
Net Weight	11.25kg		

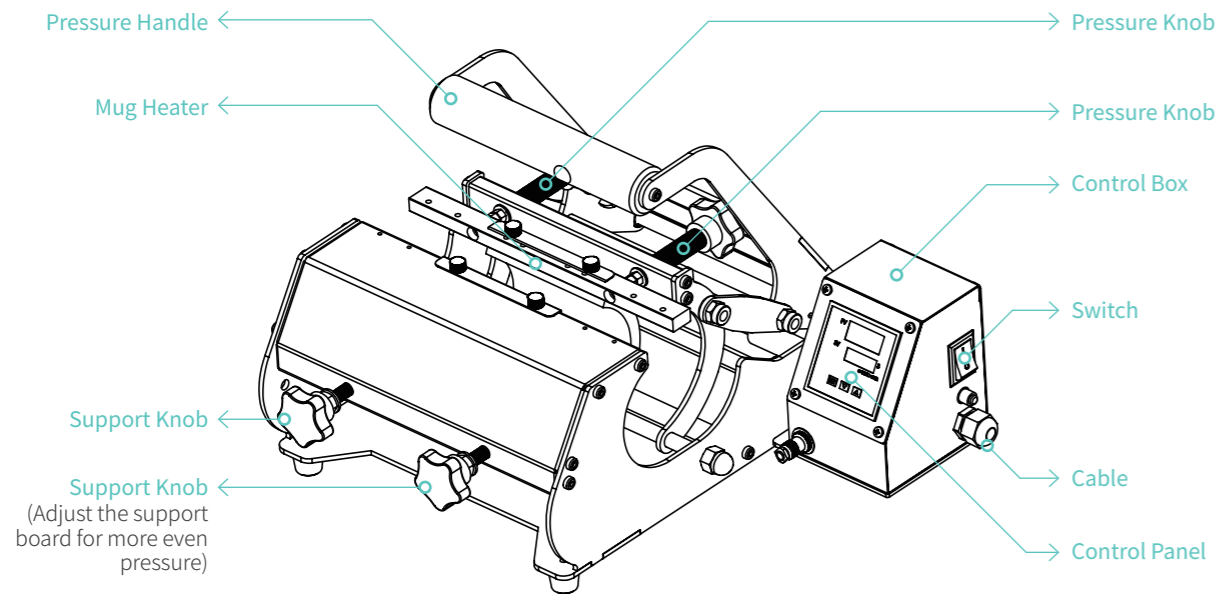

Unit: mm

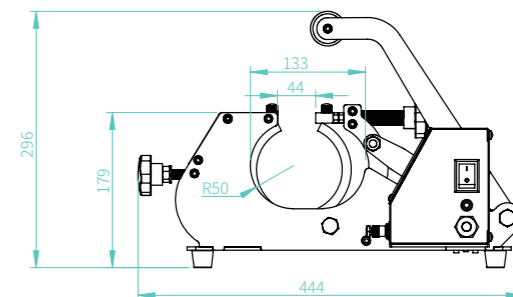
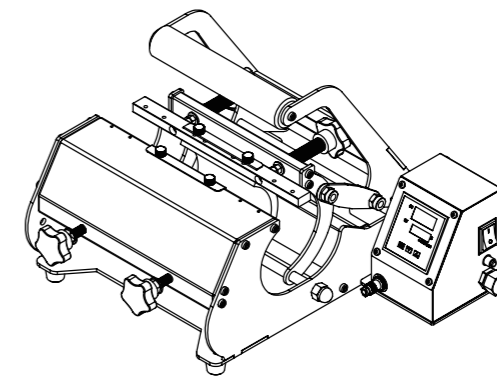
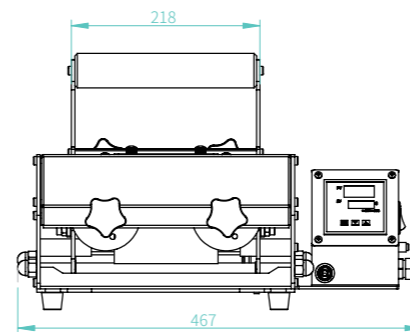
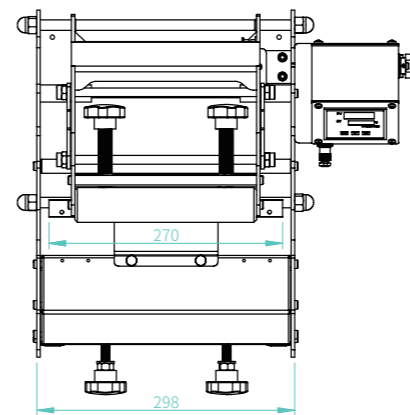

KNOW THE CONTROL PANEL

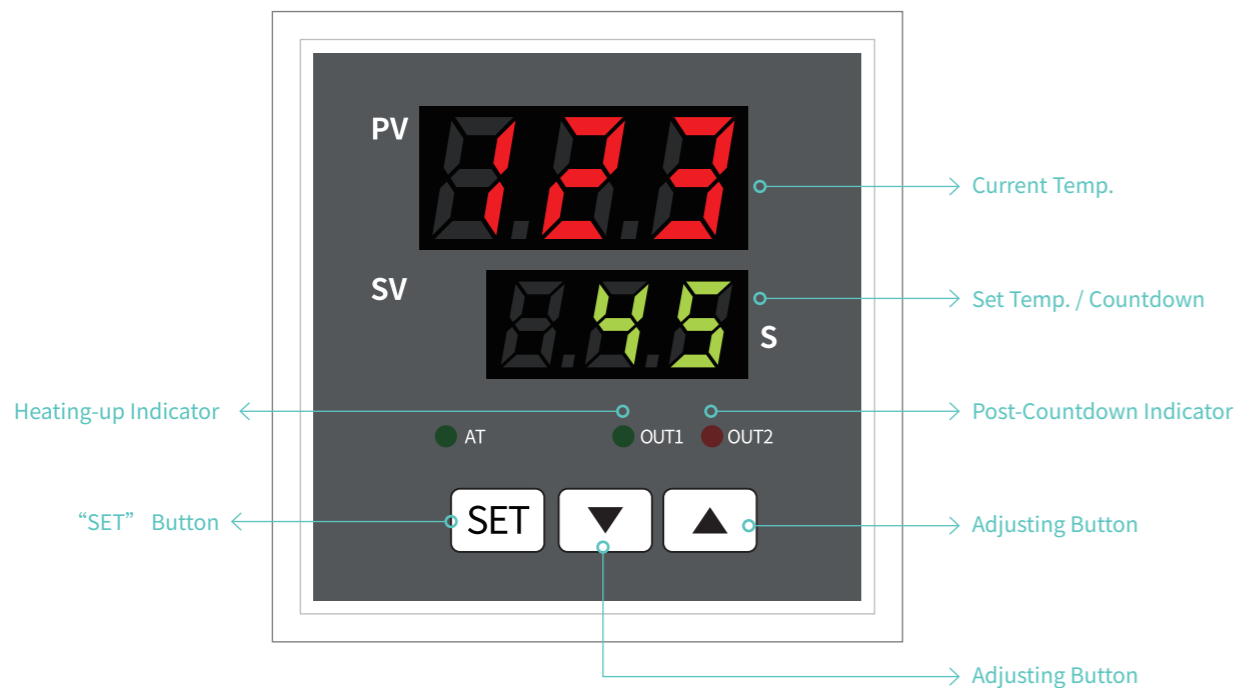

HOW TO SWITCH BETWEEN °C AND °F ?

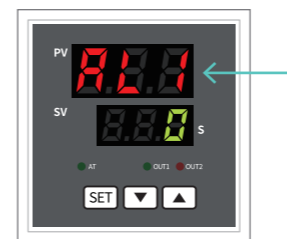

1. Turn on the machine, long press "SET" button for 5 seconds, and the screen displays as shown above;

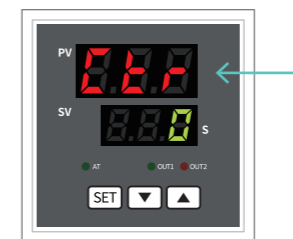

2. Press "SET" button for 9 times to enter switching mode, and the screen displays as shown above;

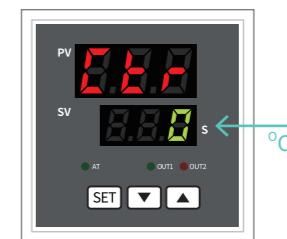

3. Press "▼" and "▲" to switch between °C and °F . "0" indicates °C , while "1" indicates °F . Then long press "SET" button for 5 seconds to save the setting and exit.

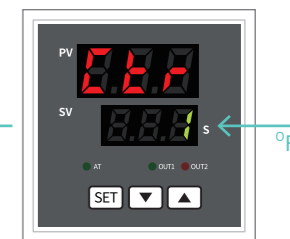

HOW TO SET PARAMETERS?

1. Press "SET" button to enter temperature setting mode, then press "▼" and "▲" to adjust the temperature value;
2. Press "SET" button again to enter time setting mode, then press "▼" and "▲" to adjust the time value;
3. Press "SET" button one last time to save the settings.

HOW TO USE?

1. Print on sublimation paper;
2. Fix the image paper on a blank mug using thermal tape;
3. Put the mug into the heater, and adjust the printing pressure.
4. To ensure even pressure, turn the knobs of support board to make it closer to support the mug heater;
5. Take out the mug, plug in and turn on the machine;
6. Set printing time and temperature;
7. Wait until the machine heats up to the set temperature;
8. Put the mug into the heater, press down the handle, and the machine starts countdown;
9. After countdown, take out the mug and check the result.

Printing Parameters

No.	Item Name	Temp.	Time(S)	Remark
1	Stainless Steel Skinny Tumbler	180°C (356 °F)	60	1. Print on sublimation paper, mirror image; 2. Take off the lid before printing; 3. Use low pressure.
2	Ceramic/Glass Mug	180°C (356 °F)	280	1. Print on sublimation paper, mirror image; 2. Place the mug into the heater in proper position to avoid handle breaking; 3. Use medium pressure
3	Water Bottle (Aluminum/ Stainless Steel Material)	180°C (356 °F)	60	1. Print on sublimation paper, mirror image; 2. Take off the lid before printing; 3. Use low pressure.
4	Plastic Mug	180°C (356 °F)	280	1. Print on sublimation paper, mirror image; 2. Put the printing tool into the mug before printing to avoid deformation; 3. Use low pressure.

1. The parameters above are just for PYDLife heat press machines.
2. The parameters above are for reference only. Please test to find the best parameters for your own product.

Safety Instructions

1. Don't touch the heat platen as the machine is heating.
2. Don't touch the heat platen and silicon mat when the machine remains hot.
3. This machine is not intended for use by children.



NOTES:

1. Do not heat the machine without a mug inside in case of burnout.
2. Do not touch the heater directly without any protection.
3. If the machine works for more than 1.5 hours, it is better to turn it off for a 20-minute break.

FAQS:

Colors are lighter	The temperature is too low, the pressure is uneven, or the time is too short.
Printed picture is vague	The printing time is long, which causes the ink spread.
Colors are less bright	The pressure is too high or the temperature is too high.
Printed picture is partially vague	The heat is uneven.
Colors are different	The pressure is uneven or the surface of the printed item is uneven.
The paper sticks on the printed item	The temperature is too high or the coating of the item is in poor quality.